

Clearfree®



750W SUBMERSIBLE PUMP MODEL NO: HIPPO 5A

PART NO: 7230536

OPERATION & MAINTENANCE INSTRUCTIONS



ORIGINAL INTRUCTIONS

LS0917 - iss 2

INTRODUCTION

Thank you for purchasing this CLARKE 750W Submersible pump.

This pump is designed for pumping clean water only. **It is NOT designed for pumping slurry, sludge, mud or heavily polluted water, or any water containing chemicals or other acidic contaminants including salt water.**

GUARANTEE

This product is guaranteed against faulty manufacture for a period of 12 months from the date of purchase. Please keep your receipt which will be required as proof of purchase.

This guarantee is invalid if the product is found to have been abused or tampered with in any way, or not used for the purpose for which it was intended.

Faulty goods should be returned to their place of purchase, no product can be returned to us without prior permission.

This guarantee does not effect your statutory rights.

ENVIRONMENTAL RECYCLING POLICY



Through purchase of this product, the customer is taking on the obligation to deal with the WEEE in accordance with the WEEE regulations in relation to the treatment, recycling & recovery and environmentally sound disposal of the WEEE.

In effect, this means that this product must not be disposed of with general household waste. It must be disposed of according to the laws governing Waste Electrical and Electronic Equipment (WEEE) at a recognised disposal facility.

OVERLOAD SWITCH

These pumps are fitted with a thermal overload switch. If the pump overheats for any reason, it will automatically switch the pump OFF. Once the pump has cooled (at least 5-10 minutes), the pump will automatically restart.

SAFETY INSTRUCTIONS

GENERAL

1. Read all instructions before use and save these instructions for future use.
2. An approved residual current device (RCD) which has a tripping current of less than 30mA **MUST** be used for all operations.
3. The electrical supply must be the same as that on the rating plate.
4. Always make sure that your hands are dry when connecting or disconnecting from the mains supply.
5. Never pull the mains lead to disconnect the pump from the mains socket.
6. The mains plug must be kept away from the water at all times.
7. Do not allow children or unauthorised people to touch the pump, cables or connections.
8. Disconnect the pump from the mains supply when not in use.
9. If necessary have the pump repaired by a qualified person.
10. Keep the mains lead away from heat, oil and sharp edges.
11. If you have to use an extension lead with this product, it must be designed for outdoor use and incorporate a cable suitable for use with Class I appliances.
12. Disconnect the pump from the electrical supply and wear gloves during servicing or maintenance.

PUMP SPECIFIC

1. Do not pump explosive / flammable liquids or chemicals.
2. Never allow the pump to run dry or operate out of the water.
3. Submersible pumps should always be submerged and stored vertically.
4. Disconnect the pump from the mains supply before placing it into or removing it from the water.
5. Always check the plug, and all cables for damage before use.
6. Do not use the pump if damaged. Refer to qualified service personnel for repair.
7. Never carry or lower the pump by the power cable or float switch always use the handle or a rope tied securely to the handle.
8. Never insert your fingers into the pump whilst it is connected to the mains.
9. Never use the submersible pump in a swimming pool when there are people or animals in the pool.
10. Keep the pump clear of any sediment by standing it on a platform or brick or suspending it at a suitable depth.
11. Do not use the pump if the water is liable to freeze, as this can cause damage to the pump. Remove the pump from the water and store it in a frost free location.

ELECTRICAL CONNECTIONS



WARNING: READ THESE ELECTRICAL SAFETY INSTRUCTIONS THOROUGHLY BEFORE CONNECTING THE PRODUCT TO THE MAINS SUPPLY.

Connect the mains lead to a standard, 230 Volt (50Hz) electrical supply through an approved 13 amp BS 1363 plug, or a suitably fused isolator switch. If the plug has to be changed because it is not suitable for your socket, or because of damage, it must be removed and a replacement fitted, following the wiring instructions shown below. The old plug must be discarded safely, as insertion into a power socket could cause an electrical hazard.



**WARNING: THE WIRES IN THE POWER CABLE OF THIS PRODUCT ARE COLOURED IN ACCORDANCE WITH THE FOLLOWING CODE:
BLUE = NEUTRAL BROWN = LIVE YELLOW AND GREEN = EARTH**

If the colours of the wires in the power cable do not agree with the markings on the plug.

- The BLUE wire must be connected to the terminal which is marked N or coloured black.
- The BROWN wire must be connected to the terminal which is marked L or coloured red.
- The YELLOW AND GREEN wire must be connected to the terminal which is marked E or \perp or coloured green.

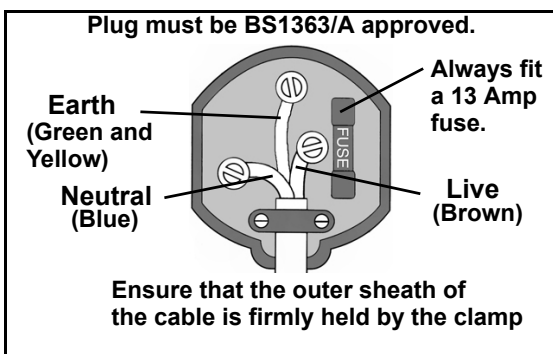

AN APPROVED RESIDUAL CURRENT DEVICE (RCD) WHICH HAS A TRIPPING CURRENT OF LESS THAN 30 mA MUST BE USED.

If you are not sure, consult a qualified electrician. DO NOT try to do any repairs.

ASSEMBLY

Remove all packaging and make sure that the unit has no visible damage. Dispose of all packaging appropriately.

FITTING THE HOSE ADAPTER

- 3 step adapter 1 1/4" hose, 1" BSP, 1" hose.
1. Screw the 3 step adapter onto the pump.
 2. Trim the adaptor to the required size.
 - Reducing the hose diameter will effect the maximum flow rate.
 - Suitable hoses are available from your local Clarke dealer.



SETTING UP THE PUMP

POSITIONING THE PUMP

1. Place the pump on a flat surface in the area that you want to drain.
 - If there is sediment in the operating area, the pump should be placed vertically on house bricks, or similar.
 - Ensure the pump is positioned with adequate space so that the movement of the float switch is not restricted - recommended minimum area of 50 x 50cm.
 - ALWAYS raise and lower the pump using a rope attached to the lifting handle, never lift/lower the pump by the mains lead.
 - Take all necessary precautions as described on page 3.

USING THE PUMP



WARNING: CHECK THE PUMP FOR DAMAGE BEFORE USE, DO NOT USE THE PUMP IF IT IS DAMAGED IN ANY WAY.

WARNING: THE WATER BEING PUMPED WILL BE POLLUTED IF THIS PUMP BECOMES DAMAGED AND LUBRICANT WITHIN THE PUMP ESCAPES.

1. Connect the mains plug to the mains supply.
 - Always use a high sensitivity residual current device (RCD) which has a tripping current of less than 30mA.
2. Switch the mains power supply on.
 - The pump will begin to drain water.
 - As the water level falls, so will the float switch, until it stops the pump.
 - You can adjust the position at which the float switch lead clips to the side of the pump. Adjusting the length of the float switch lead will change the depth of water at which the pump will turn on or off.
3. When pumping is finished, disconnect the pump from the mains power supply.

IMPORTANT: Do not allow the pump to run dry

MAINTENANCE



WARNING: BEFORE CHECKING THE CONDITION OF THE PUMP, ENSURE IT IS UNPLUGGED FROM THE MAINS SUPPLY. IF THE UNIT IS HARD WIRED, ENSURE THE CIRCUIT BREAKER IS OPEN.

This pump should require no maintenance other than regular cleaning.

If the pump starts to show signs of wear or damage, contact your CLARKE dealer for advice.

CLEANING

1. Check the pump installation regularly to ensure the water inlet is clear of leaves or other debris.
2. Take extra care to remove any debris from around the impeller.

NOTE: Do not attempt to repair the pump yourself, as you may damage the waterproof seal and invalidate your guarantee. Repairs must be carried out by your CLARKE dealer, or contact the CLARKE Service Department, on 020 8988 7400.

STORAGE

When the pump is not being used for extended periods, clean and dry it thoroughly and store in indoors. If the pump is left in water, it must be run at least once a week to prevent it from seizing up.

SPECIFICATIONS

Voltage	230V~50Hz
Outlet Thread Diameter	1¼" BSP
Power	750W
Maximum Head Height	8.5 m
Maximum Depth	7 m
Maximum Flow	208 l/min
Maximum Water Temperature	35°C
Maximum Particle Size	Clean Water Only
Weight	5.3 kg
Cable Length	10 m
Dimensions (D x W x H)	166 x 166 x 280 mm

TROUBLESHOOTING

PROBLEM	SOLUTION
PUMP WILL NOT START	<ol style="list-style-type: none"> 1. Make sure that the power is switched on. 2. Check fuse (consult an electrician if in doubt). 3. If an extension lead is fitted, check connections (consult an electrician if in doubt). 4. Internal thermal cut-out has not re-set. Leave for 5-10 minutes and try again. 5. The impeller may be jammed. Disconnect from the mains supply and remove any objects that may be obstructing the impeller. 6. Float switch may be jammed against side wall, or prevented from moving. 7. If the pump still fails to start, consult your CLARKE dealer for advice.
PUMP WILL START BUT NOT PUMP	<ol style="list-style-type: none"> 1. Check that the inlet is not blocked. 2. Check that the outlet is not clogged or obstructed. 3. The head may be too great, i.e. you are trying to lift the water too great a distance for the pump to cope with. ("Specifications" on page 7). 4. Air bubble in the pump, produced during immersion. immerse the pump again, at an angle, and shake it whilst lowering to remove any air trapped in the system. 5. Impeller may be damaged - Consult your CLARKE dealer.
PUMP WILL NOT STOP	<ol style="list-style-type: none"> 1. Float switch may be prevented from moving to the fully down position. 2. Float switch may be faulty. Consult your CLARKE dealer for advice.
PUMP STOPS RUNNING	<ol style="list-style-type: none"> 1. Thermal overload has operated. Leave for 5-10 minutes and try again. 2. Pump has run dry, or float switch has cut in. 3. A foreign object has jammed the impeller.

If this does not solve your problem, please contact the Clarke service department.

PARTS LIST & DIAGRAM

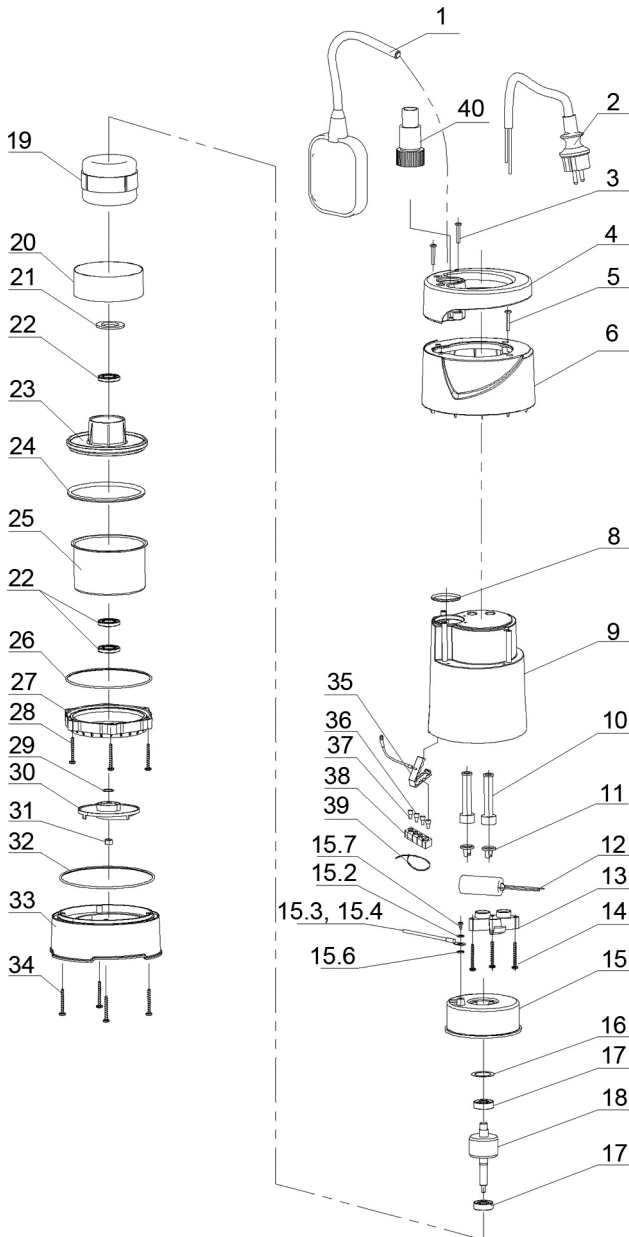

PARTS LIST

1	Mains Cable	19	Stator
2	Float Switch	20	Bushing
3	Self Tapping Screw	21	Gasket
4	Handle	22	Skeleton Seal
5	Self Tapping Screw	23	Aluminium Bushing
6	Cover Plate	24	O-ring
8	O-ring	25	Front Cover
9	Rear Pump Housing	26	O-ring
10	Cable Sheath	27	O-ring
11	Cable Gland	28	Self Tapping Screw
12	8uf Capacitor	29	Adjustable Washer
13	Cable Block	30	Impeller
14	Customized Self Tapping Screw	31	Nut
15	Rear Cover	32	O-ring
15.2	Gasket	33	Pump Base
15.3	Earth Wire (Yellow/green)	34	Self Tapping Screw
15.4	Lug Plate	35	Ground Cover
15.6	Gasket	36	Nylon Secure Pressing Cap
15.7	Bolt	37	Nylon Secure Pressing Cap
16	Wave Washer	38	Rubber Clip
17	Bearing	39	Ribbon
18	Rotor	40	Outlet Connector

Part number = (DHHIPPO5A + the number of the part)

DECLARATION OF CONFORMITY



Clarke[®]
INTERNATIONAL

Hemnal Street, Epping, Essex CM16 4LG

DECLARATION OF CONFORMITY

This is an important document and should be retained.

We hereby declare that this product(s) complies with the following directive(s):

2004/108/EC *Electromagnetic Compatibility Directive.*

2006/95/EC *Low Voltage Equipment Directive.*

2011/65/EU *Restriction of Hazardous substances.*

The following standards have been applied to the product(s):

EN 60335-1:2012, EN 60335-2-41:2003 +A1:2004 +A2:2010, EN 62233:2008, EN 61000-3-3:2008,

EN 55014-2:1997 +A1:2001 +A2:2008, EN 61000-3-2:2006 +A1:2009 +A2:2009,

EN 55014-1:2006 +A1:2009.

The technical documentation required to demonstrate that the product(s) meet(s) the requirement(s) of the aforementioned directive(s) has been compiled and is available for inspection by the relevant enforcement authorities.

The CE mark was first applied in: 2012

Product Description:	Submersible/ Puddle pump(s)
Model number(s):	HIPPO5A, CSV4A, PSP105, PSP125B, PSV6A, PSV7A, PSV5A
Serial / batch Number:	N/A
Date of Issue:	24/03/2015

Signed:

J.A. Clarke
Director

A SELECTION FROM THE VAST RANGE OF

Clarke®

QUALITY PRODUCTS

AIR COMPRESSORS

From DIY to industrial, Plus air tools, spray guns and accessories.

GENERATORS

Prime duty or emergency standby for business, home and leisure.

POWER WASHERS

Hot and cold, electric and engine driven - we have what you need

WELDERS

Mig, Arc, Tig and Spot. From DIY to auto/industrial.

METALWORKING

Drills, grinders and saws for DIY and professional use.

WOODWORKING

Saws, sanders, lathes, mortisers and dust extraction.

HYDRAULICS

Cranes, body repair kits, transmission jacks for all types of workshop use.

WATER PUMPS

Submersible, electric and engine driven for DIY, agriculture and industry.

POWERTOOLS

Angle grinders, cordless drill sets, saws and sanders.

STARTERS/CHARGERS

All sizes for car and commercial use.

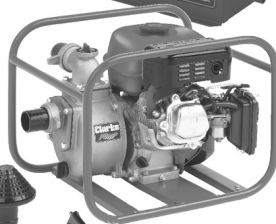

PARTS & SERVICE: 0208 988 7400

E-mail: Parts@clarkeinternational.com or Service@clarkeinternational.com

SALES: UK 01992 565333 or Export 00 44 (0)1992 565335

Clarke® INTERNATIONAL Hemnall Street, Epping, Essex CM16 4LG
www.clarkeinternational.com